



COOLING TECHNOLOGY INSTITUTE

P. O. Box 681807, Houston, Texas 77268 • 3845 Cypress Creek Parkway, Ste 420, Houston, Texas 77068
Phone: 281.583.4087 • Fax: 281.537.1721 • email: vmanser@cti.org • http://www.cti.org

Advance Cooling Towers Pvt. Ltd.
Advance 2020 – NTM Line of CTI Certified Cooling Towers
CTI Certification Validation Number C31B-19R00
September 23, 2019 (Revision 0)

(Note: Number of Certified Cells Denoted by Prefix 1 through 6)

NTM81KW2.2	NTM144KW7.5
NTM81KW3.75	NTM144KW9.3
NTM99KW2.2	NTM162KW9.3
NTM99KW3.75	NTM162KW11.0
NTM117KW3.75	NTM180KW11.0
NTM117KW5.5	NTM180KW15.0
NTM135KW5.5	
NTM135KW7.5	

See Footnotes, Next Page

CTI CERTIFIED "SERIES NTM LINE OF COOLING TOWER"

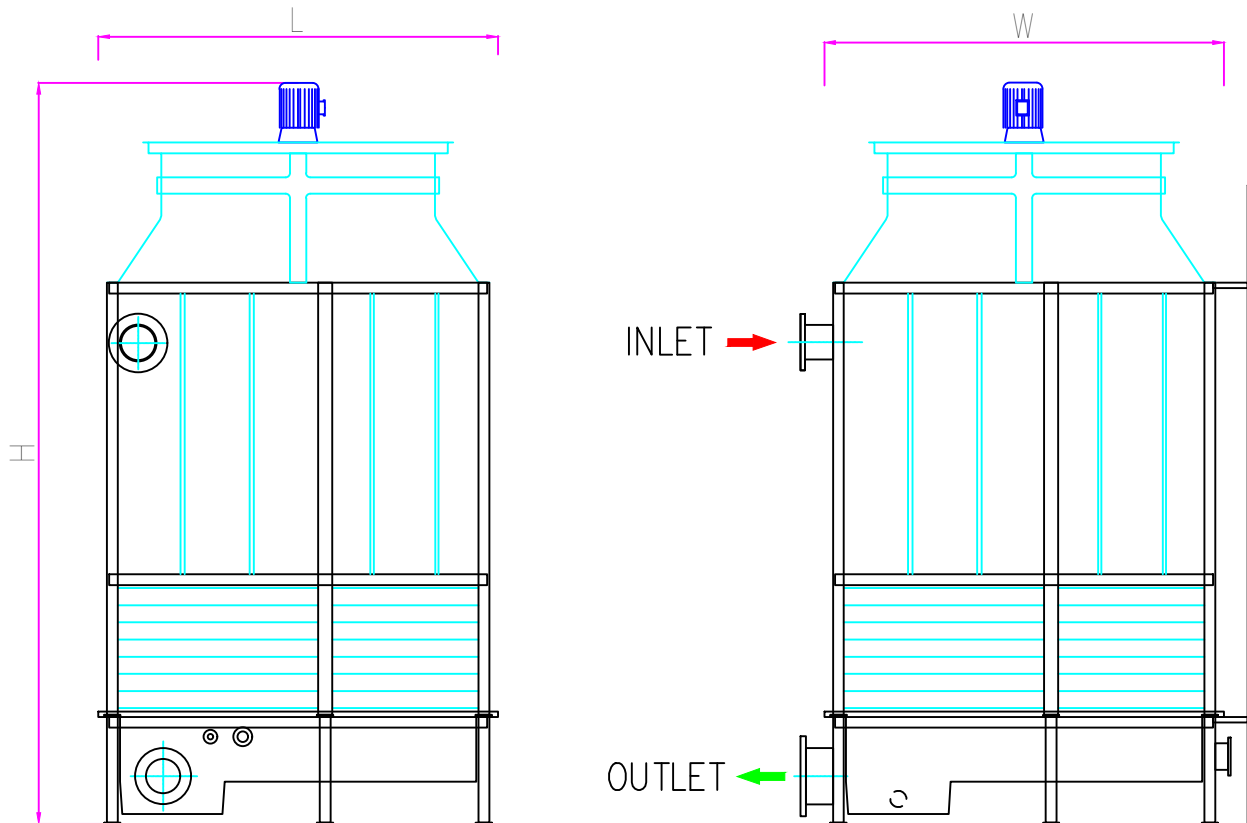

	DIMENSIONS OF "SERIES – NTM" COOLING TOWERS						
Series "NTM" Model No	L mm	W mm	H mm	INLET Inches	OUTLET Inches	DRY WEIGHT Kg	OP. WEIGHT Kg
1NTM81	1850	1850	3430	4"	4"	629	1656
1NTM99	2100	2100	3430	6"	6"	700	2023
1NTM117	2600	2600	3550	6"	6"	938	2966
1NTM135	2850	3100	3580	8"	8"	1165	3815
1NTM144	3100	3600	3650	8"	8"	1323	4671
1NTM162	3600	3600	3835	8"	8"	1530	5418
1NTM180	4100	4100	4235	10"	10"	1982	7025

NOTES: → DIMENSIONS GIVEN ABOVE ARE WITH BASIN FROM 1NTM81 TO 1NTM180

C31A Advance 2020 NTM Line of CTI Certified Cooling Towers

Advance 2020 Website:

<https://advancecoolingtowers2020.com/>